



Automation for a Changing World

# Delta Fan/Pump Vector Control Drive CP2000 Series



[www.deltaww.com](http://www.deltaww.com)

 **DELTA**  
Smarter. Greener. Together.

# WHY CP2000?

## IABG green technology

Delta Industrial Automation Business Group IABG introduces the CP2000 series AC motor drive for energy-saving HVAC systems and for pump and fan applications. The CP2000 series is equipped with special HVAC parameters and PID control functions for efficient operation, as well as multi-segment V/F control curve and soft start functions to assist frequent torque change and constant output applications with energy-saving performance.





**CP2000**

# Water Circulation Pump Control

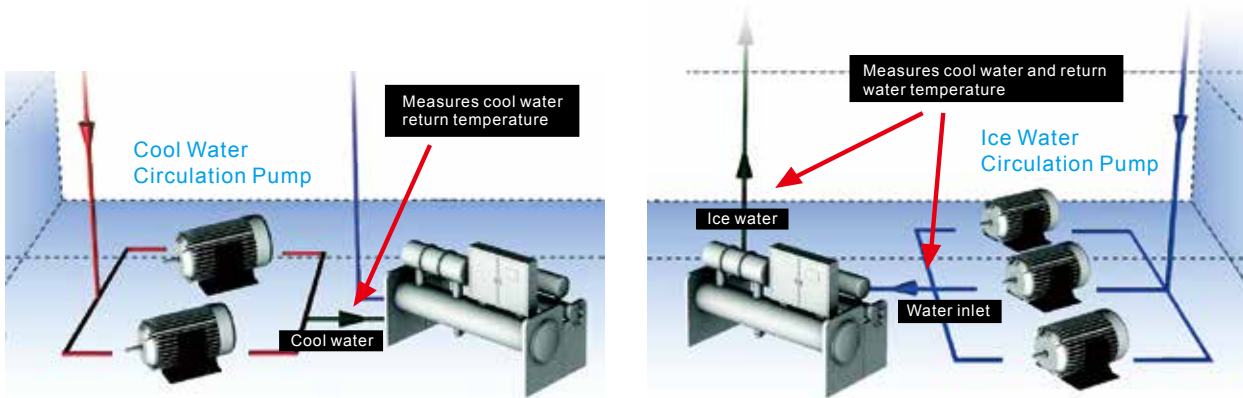

Figure1:Multi-Pumps Control

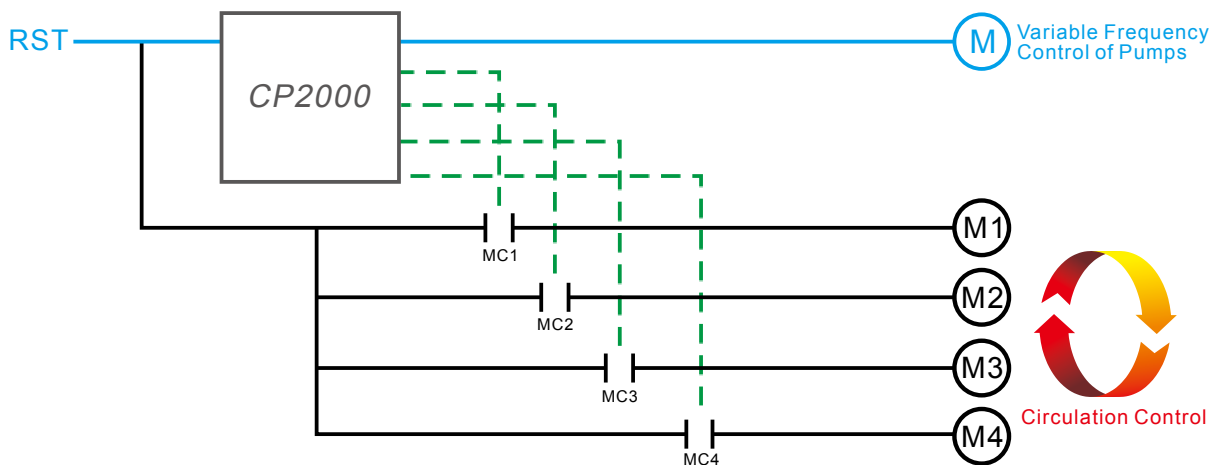

Figure 2: Fixed Amount and Circulation Control

## Features

- ▶ LCD keypad - An easy-to-use text panel with TP Editor software allows users to self-define the main page screen
- ▶ Quick setting - Allows users to self-define the parameter groups and duplicate parameter for fast and easy installation
- ▶ Modular design - Provides flexible extension and is easy to maintain
- ▶ High-speed communications include BACnet and MODBUS, optional communication cards are available upon purchase: PROFIBUS-DP, DeviceNet, MODBUS TCP, EtherNet-IP and CANopen
- ▶ Extended life cycle
- ▶ PCB (Printed Circuit Board) - Enhances drive durability in critical environments
- ▶ Fire mode and bypass functions - Provides continuous pressure to extract smoke when emergencies occur
- ▶ Various modes for fans/pumps applications - PID control, sleep/wake up functions, flying start and skip frequency
- ▶ Multi-pumps control - Synchronously controls up to 8 motors at one time and provides fixed amount and fixed time circulation control
- ▶ Built-in 10K step PLC programming capacity and Real Time Clock (RTC)

# Advanced Drive Technology

## High Performance Variable Frequency Drive Technology

- 1.SVC Sensorless vector control
- 2.Dual rating design (Light duty & Normal duty)
- 3.Excellent variable torque control asynchronous motors

## Modular Design

- 1.Hot plug LCD keypad
- 2.I/O extension card
- 3.Various communication cards
- 4.Removable fans



## Versatile Drive Control

- 1.Built-in PLC function
- 2.Built-in brake unit\*
- 3.Networking drive system
- 4.Auto energy saving

## Environmental Adaptability

- 1.50°C operation temperature
- 2.Built-in DC choke\*
- 3.Coated circuit boards
- 4.Built-in EMI filter\*
- 5.International standard of safety: CE/UL/CUL

\*Note: Please refer to the Product Specification for more detail.

# Standard Models

Power range: 230V 0.75~90kW, 460V: 0.75~400kW

230V (kW)	0.75	1.5	2.2	3.7	5.5	7.5	11	15	18.5	22	30	37	45	55	75	90
230V (HP)	1	2	3	5	7.5	10	15	20	25	30	40	50	60	75	100	125
Frame Size	A					B			C		D		E			

460V (kW)	0.75	1.5	2.2	3.7	4.0	5.5	7.5	11	15	18.5	22	30	37
460V (HP)	1	2	3	5	5	7.5	10	15	20	25	30	40	50
Frame Size	A							B			C		

460V (kW)	45	55	75	90	110	132	160	185	220	280	315	355	400
460V (HP)	60	75	100	125	150	175	215	250	300	375	425	475	536
Frame Size	D0		D		E		F		G		H		

# Standards

### ■ CE

Low Voltage:  
EN61800-5-1

### EMC:

EN61000-3-12, EN61800-3,  
IEC61000-6-2, IEC61000-6-4,  
IEC61000-4-2, IEC61000-4-3,  
IEC61000-4-4, IEC61000-4-5,  
IEC61000-4-6, IEC61000-4-8

### ■ UL, cUL

### ■ C-Tick

### ■ ROHS



# High-Speed Network

- **Advanced network functions**

- Built-in MODBUS RS-485
- Built-in BACnet MS/TP



- **Provides various communication network cards and field bus cards**

- **CANopen (DS402), MODBUSTCP,**



# Building Automation Applications

- 4-points adjustable V/F control - Real-time adjustment of input voltage under variable torque load environments, especially for pump and fan applications.
- Flying start and auto restart after momentary power loss functions, suitable for fans application.
- Skip frequency function avoids mechanical resonance and protects the equipment.
- Low-current protection function prevents free load operation.
- Built-in BACnet communication protocol, saves on the wiring for building automation application.

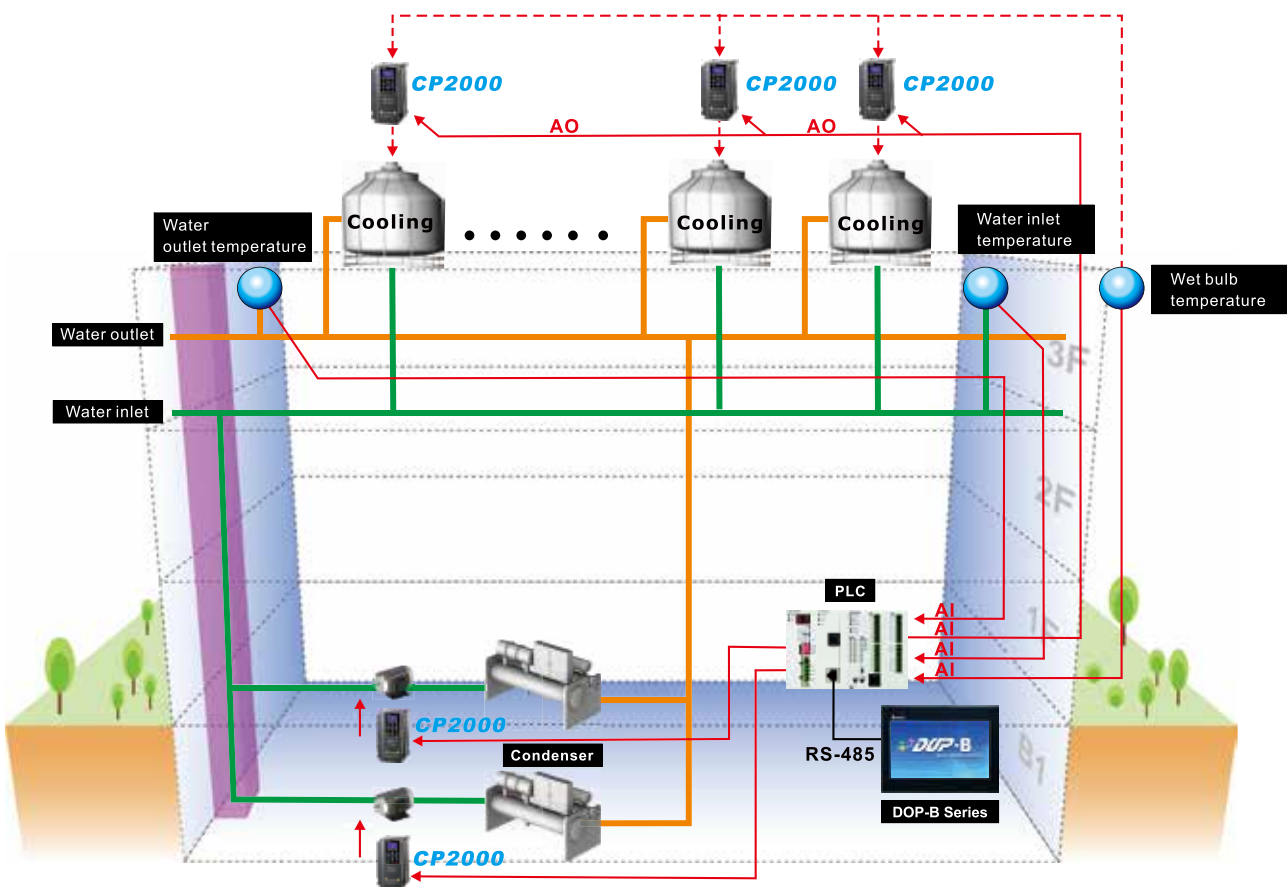

## Improves Motor Performance

- Sensorless Vector Control (SVC) and auto-tuning functions to improve motor performance for variable torque load applications.
- Deceleration Energy Backup (dEb) function decelerates motor to a stop when sudden power failure occurs to protect the equipment from damage.
- Auto adjusting acceleration/deceleration speed, reduces mechanical vibration when activating and stopping the equipment and provides smooth operation.
- Energy saving control functions include PID control, sleep/wakeup mode and auto-energy saving mode.

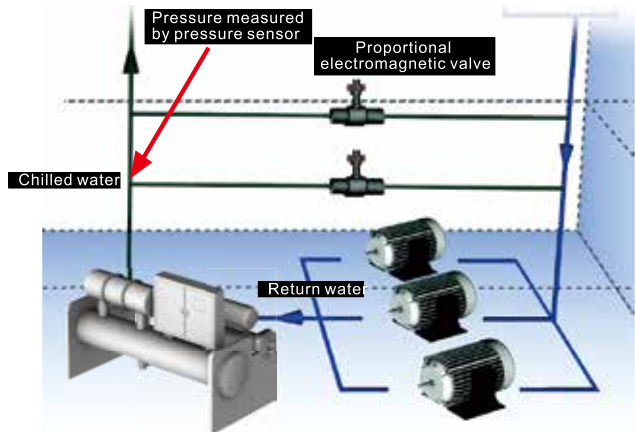
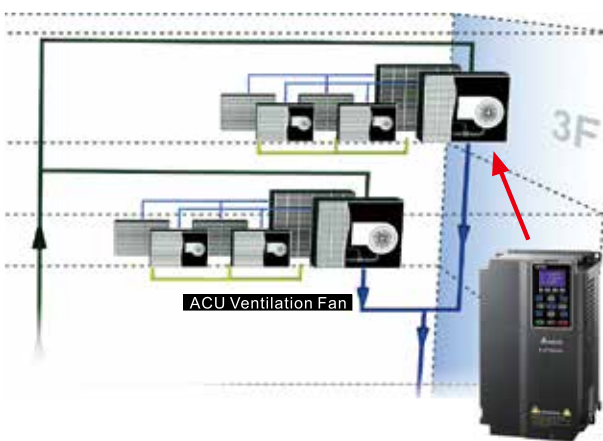

## Built-in PLC Function

- Built-in 10K steps PLC function supports independent and distributed control when connecting to a network system for high operation flexibility .
- Real Time Clock (RTC) function facilitates the PLC program writing process for ON/OFF chronology, daylight saving operation and many other settings.

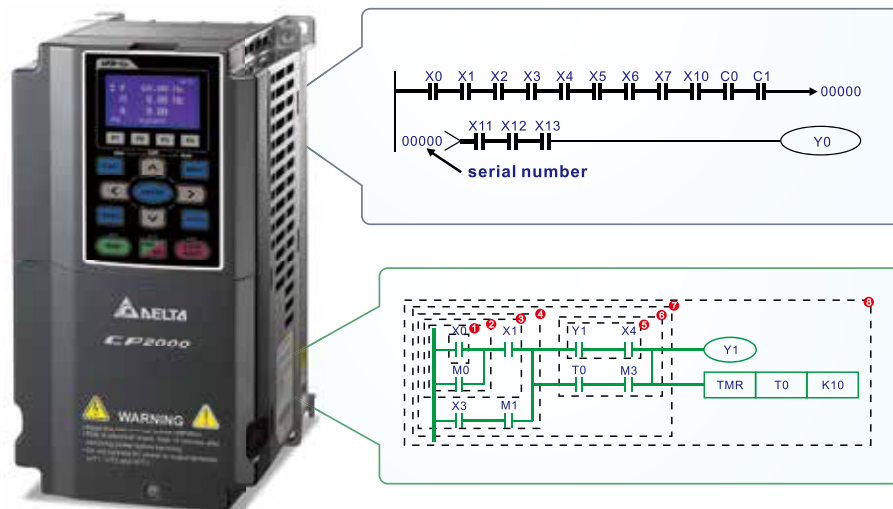

## Modular Design

Powerful motor drive control functions. The modular design satisfies various system applications with higher flexibility and is easy to maintain. Accessories include input/output extension cards, communication cards, hot plug LCD keypad, removable terminal blocks and removable fans.

- KPC-CC01 keypad
- Standard RJ45 cable for distanced operation.
- Easy to install and remove with one press.



■ RFI Switch



- Removes the safety screws on the top cover. Press on two sides to remove the cover.



- The product nameplate shows the input/output voltage, input / output current, frequency range, and more.



- Modularized fan design, easy to replace and clean, extends product life.



## High Adaptability to Environment

- Built-in DC choke to suppress harmonics\*
- Built-in EMI filter to filter noise\*
- Enhanced coating on the control board's PCB to ensure reliability of VFD in an adverse environment.
- The electronic components of the drive are isolated from the cooling system to reduce heat interference. Dissipated heat can be discharged by flange-mounting installation, and forced fan cooling can import cold air into the heat sink. The heat dissipation performance is optimized by these two cooling methods.



\*Note: Please refer to the Product Specification for more detail



# Environment for Operation, Storage and Transportation

DO NOT expose the AC motor drive in harsh environments, such as dust, direct sunlight, corrosive/ inflammable gasses, humidity, liquid or vibrations. The salt in the air must be less than 0.01mg/cm<sup>2</sup> per year.

Environment	<b>Installation location</b>	IEC60364-1/IEC60664-1 Pollution degree 2, Indoor use only	
	<b>Surrounding Temperature</b>	Storage/ Transportation	-25°C ~ +70°C
		No condensation, no frost	
	<b>Rated Humidity</b>	Operation	Max. 90%
		Storage/ Transportation	Max. 95%
		No condensation, no frost	
	<b>Air Pressure</b>	Operation/ Storage	86 to 106 kPa
		Transportation	70 to 106 kPa
	<b>Pollution Level</b>	IEC60721-3-3	
		Operation	Class 3C2; Class 3S2
Storage		Class 2C2; Class 2S2	
Transportation		Class 1C2; Class 1S2	
<b>Altitude</b>	No condensation, no frost		
	Operation	If AC motor drive is installed at altitude 0~1000m, follow normal operation restriction. If it is install at altitude 1000~3000m, decrease 2% of rated current or lower 0.5°C of temperature for every 100m increase in altitude. Maximum altitude for Corner Grounded is 2000m.	
<b>Package Drop</b>	Storage/ Transportation	ISTA procedure 1A(according to weight) IEC60068-2-31	
<b>Vibration</b>	1.0mm, peak to peak value range from 2Hz to 13.2 Hz; 0.7G~1.0G range from 13.2Hz to 55Hz; 1.0G range from 55Hz to 512 Hz. Complies with IEC 60068-2-6		
<b>Impact</b>	IEC/EN 60068-2-27		
<b>Operation Position</b>	Max. allowed offset angle ±10°C (under normal installation position)		

# Specification for Operation Temperature and Protection Level

Model	Frame	Top Cover	Conduit Box	Protection Level	Operation Temperature
VFDxxxxCPxxx-21	Frame A ~ C 230V: 0.75 ~ 30kW 460V: 0.75 ~ 37kW	Remove top cover	Standard conduit plate	IP20/UL Open Type	ND: -10°C ~ 50°C LD: -10°C ~ 40°C
		Standard with top cover		IP20/UL Type1/NEMA1	ND: -10°C ~ 40°C LD: -10°C ~ 40°C
	Frame D ~ H 230V: >37kW 460V: >45kW	N/A	Conduit box	IP20/UL Type1/NEMA1	ND: -10°C ~ 40°C LD: -10°C ~ 40°C
VFDxxxxCPxxx-00	Frame D ~ H 230V: >37kW 460V: >45kW	N/A	No conduit box	IP00 IP20/UL Open Type 	ND: -10°C ~ 50°C LD: -10°C ~ 40°C (ND=Normal Duty LD=Light Duty)

# Product Specifications

230V

Frame Size		A					B			C			D		E			
Model : VFD-____CP23-__		007	015	022	037	055	075	110	150	185	220	300	370	450	550	750	900	
Output Rating	Light Duty	Rated Output Capacity (kVA)	2.0	3.0	4.0	6.0	8.4	12	18	24	30	36	42	58	72	86	110	128
		Rated Output Current (A)	5	7.5	10	15	21	31	46	61	75	90	105	146	180	215	276	322
		Applicable Motor Output(kW)	0.75	1.5	2.2	3.7	5.5	7.5	11	15	18.5	22	30	37	45	55	75	90
		Applicable Motor Output(HP)	1	2	3	5	7.5	10	15	20	25	30	40	50	60	75	100	125
		Overload Tolerance	120% of rated current for 1 minute															
		Max. Output Frequency (Hz)	600.00Hz												400.00Hz			
		Carrier Frequency (kHz)	2~15kHz(8KHz)						2~10kHz(6KHz)						2~9kHz(4KHz)			
	Normal Duty	Rated Output Capacity (kVA)	1.2	2.0	3.2	4.4	6.8	10	13	20	26	30	36	48	58	72	86	102
		Rated Output Current (A)	3	5	8	11	17	25	33	49	65	75	90	120	146	180	215	255
		Applicable Motor Output(kW)	0.4	0.75	1.5	2.2	3.7	5.5	7.5	11	15	18.5	22	30	37	45	55	75
		Applicable Motor Output(HP)	0.5	1	2	3	5	7.5	10	15	20	25	30	40	50	60	75	100
		Overload Tolerance	120% of rated current for 1 minute; 160% of rated current for 3 seconds															
		Max. Output Frequency (Hz)	600.00Hz												400.00Hz			
		Carrier Frequency (kHz)	2~15kHz(8KHz)						2~10kHz(6KHz)						2~9kHz(4KHz)			
Input Rating	Input Current (A) Light Duty	6.4	9.6	15	22	25	35	50	65	83	100	116	146	180	215	276	322	
	Input Current (A) Normal Duty	3.9	6.4	12	16	20	28	36	52	72	83	99	124	143	171	206	245	
	Rated Voltage/Frequency	3-Phase AC 200V~240V(-15%~+10%), 50/60Hz																
	Operating Voltage Range	170~265Vac																
	Frequency Tolerance	47~63Hz																
Efficiency (%)	96	96	96	96	96	96.5	96.5	96.5	96.5	96.5	96.5	97	97	97	97	97	97	
Cooling Method	Natural Cooling	Fan Cooling																
Braking Chopper	Frame A, B, C: Built-in										Frame D and above: Optional							
DC Choke	Frame A, B, C: Optional										Frame D and above: Built-in 3%							
EMI Filter	Optional																	

460V

Frame Size		A					B			C						
Models : VFD-____CP43-__ VFD-____CP4E-__		007	015	022	037	040	055	075	110	150	185	220	300	370		
Output Rating	Light Duty	Rated Output Capacity (kVA)	2.4	3.3	4.4	6.8	8.4	10.4	14.3	19	25	30	36	48	58	
		Rated Output Current (A)	3	4.2*	5.5*	8.5*	10.5	13*	18*	24*	32*	38*	45	60*	73*	
		Applicable Motor Output(kW)	0.75	1.5	2.2	3.7	4.0	5.5	7.5	11	15	18.5	22	30	37	
		Applicable Motor Output(HP)	1	2	3	5	5	7.5	10	15	20	25	30	40	50	
		Overload Tolerance	120% of rated current for 1 minute													
		Max. Output Frequency (Hz)	600.00Hz													
		Carrier Frequency (kHz)	2~15kHz(8KHz)										2~10kHz(6KHz)			
	Normal Duty	Rated Output Capacity (kVA)	2.2	2.4	3.2	4.8	7.2	8.4	10	14	19	25	30	36	48	
		Rated Output Current (A)	1.7	3.0	4.0	6.0	9.0	10.5	12	18	24	32	38	45	60	
		Applicable Motor Output(kW)	0.4	0.75	1.5	2.2	3.7	4.0	5.5	7.5	11	15	18.5	22	30	
		Applicable Motor Output(HP)	0.5	1	2	3	5	5	7.5	10	15	20	25	30	40	
		Overload Tolerance	120% of rated current for 1 minute; 160% of rated current for 3 seconds													
		Max. Output Frequency (Hz)	600.00Hz													
		Carrier Frequency (kHz)	2~15kHz(8KHz)										2~10kHz(6KHz)			
Input Rating	Input Current (A) Light Duty	4.3	6.0	8.1	12.4	16	20	22	26	35	42	50	66	80		
	Input Current (A) Normal Duty	3.5	4.3	5.9	8.7	14	15.5	17	20	26	35	40	47	63		
	Rated Voltage/Frequency	3-Phase AC 380V~480V(-15%~+10%), 50/60Hz														
	Operating Voltage Range	323~528Vac														
	Frequency Tolerance	47~63Hz														
Efficiency (%)	96	96	96	96	96	96	96	96	96.5	96.5	96.5	96.5	96.5	96.5		
Cooling Method	Natural Cooling	Fan Cooling														
Braking Chopper	Frame A, B, C: Built-in															
DC Choke	Frame A, B, C: Optional															
EMI Filter	Frame A, B, C of VFD____CP4E-__ : Built-in Frame A, B, C of VFD____CP43-__ : N/A															

\*Rated current for B type model (e.g. VFD015CP43B-21) .

**460V**

Frame Size		D0		D		E		F		G		H			
Models : VFD- ____ CP43 _ _		450	550	750	900	1100	1320	1600	1850	2200	2800	3150	3550	4000	
Output Rating	Light Duty	Rated Output Capacity (kW)	73	88	120	143	175	207	247	295	367	422	491	544	613
		Rated Output Current (A)	91	110	150*	180	220	260*	310	370*	460	530	616	683	770
		Applicable Motor Output(kW)	45	55	75	90	110	132	160	185	220	280	315	355	400
		Applicable Motor Output(HP)	60	75	100	125	150	175	215	250	300	375	425	475	536
		Overload Tolerance	120% of rated current for 1 minute												
	Normal Duty	Max. Output Frequency (Hz)	600.00Hz					400.00Hz							
		Carrier Frequency (kHz)	2~10kHz(6KHz)					2~9kHz(4KHz)							
		Rated Output Capacity (kVA)	58	73	88	120	143	175	207	247	295	367	438	491	544
		Rated Output Current (A)	73	91	110	150	180	220	260	310	370	460	550	616	683
		Applicable Motor Output(kW)	37	45	55	75	90	110	132	160	185	220	280	315	355
Input Rating	Applicable Motor Output(HP)	50	60	75	100	125	150	175	215	250	300	375	425	475	
	Overload Tolerance	120% of rated current for 1 minute; 160% of rated current for 3 seconds													
	Max. Output Frequency (Hz)	600.00Hz					400.00Hz								
	Carrier Frequency (kHz)	2~10kHz(6KHz)					2~9kHz(4KHz)								
	Input Current (A) Light Duty	91	110	150	180	220	260	310	370	460	530	616	683	770	
	Input Current (A) Normal Duty	74	101	114	157	167	207	240	300	380	400	494	555	625	
	Rated Voltage/Frequency	3-Phase AC 380V~480V( -15%~+10%), 50/60Hz													
	Operating Voltage Range	323~528Vac													
	Frequency Tolerance	47~63Hz													
	Efficiency (%)	97	97	97	97	97	97	97	97	97.5	97.5	97.5	97.5	97.5	
Cooling Method	Fan Cooling														
Braking Chopper	Frame D and above: Optional														
DC Choke	Frame D and above: Built-in 3%														
EMI Filter	Frame D and above: Optional														

Control Characteristics	Control Method	Pulse Width Modulation (PWM)																			
	Control Mode	1: V/F(V/F control), 2: SVC(Sensorless Vector Control)																			
	Starting Torque	Reach up to 150% or above at 0.5Hz																			
	V/F Curve	4 point adjustable V / F curve and square curve																			
	Speed Response Ability	5Hz																			
	Torque Limit	Light Duty: Max. 130% torque current; Normal Duty: Max. 160% torque current																			
	Torque Accuracy	±5%																			
	Max. Output Frequency (Hz)	230V series: 600.00Hz (55kW and above: 400.00Hz) 460V series: 600.00Hz (90kW and above: 400.00Hz)																			
	Frequency Output Accuracy	Digital command:±0.01%, -10°C~+40°C, Analog command: ±0.1%, 25±10°C																			
	Output Frequency Resolution	Digital command: 0.01Hz, Analog command: max. output frequency*0.03/60Hz (±11 bit)																			
	Overload Tolerance	Light duty: 120% of rated current for 1 minute; Normal duty: 120% of rated current for 1 minute;160% of rated current for 3 seconds																			
	Frequency Setting Signal	0~+10V, 4~20mA, 0~20mA, pulse input																			
	Accel. / Decel. Time	0.00~600.00/0.0~6000.0 seconds																			
	Main Control Function	Fault restart	Torque limit	Smart stall	Dwell	3-wire sequence	Speed search	Parameter copy	JOG frequency	Slip compensation	Torque compensation	S-curve accel/dec	Energy saving control	Accel/Decel. Time switch	Frequency upper/lower limit settings	Momentary power loss ride thru	PID control (with sleep function)	Auto-Tuning (rotational, stationary)	DC injection braking at start/stop	BACnet Communication	MODBUS communication (RS-485 RJ45, max. 115.2 kbps)
	Fan Control	<b>230V series:</b> Models higher than VFD185CP23 (included) are PWM control; Models lower than VFD150CP23 (not included) are on / off switch control. <b>460V series:</b> Models higher than VFD220CP43 (included) are PWM control; Models lower than VFD185CP43 (not included) are on / off switch control.																			
Protection Characteristics	Motor Protection	Electronic thermal relay protection																			
	Over-current Protection	Light Duty: Over-current protection for 200% rated current, Normal Duty: Over-current protection for 240% rated current, Current clamp [Light duty: 130~135%] [Normal duty: 170~175%]																			
	Over-voltage Protection	230: drive will stop when DC-BUS voltage exceeds 410V 460: drive will stop when DC-BUS voltage exceeds 820V																			
	Over-temperature Protection	Built-in temperature sensor																			
	Stall Prevention	Stall prevention during acceleration, deceleration and running independently																			
	Restart After Instantaneous Power Failure	Parameter setting up to 20 seconds																			
	Grounding Leakage Current Protection	Leakage current is higher than 50% of rated current of the AC motor drive																			
International Certifications	 CE    UL    GB 12668.3    EAC																				

# Wiring

## CP2000 Series

Wiring Diagram for Frame A-C  
\*It provides 3-phase power

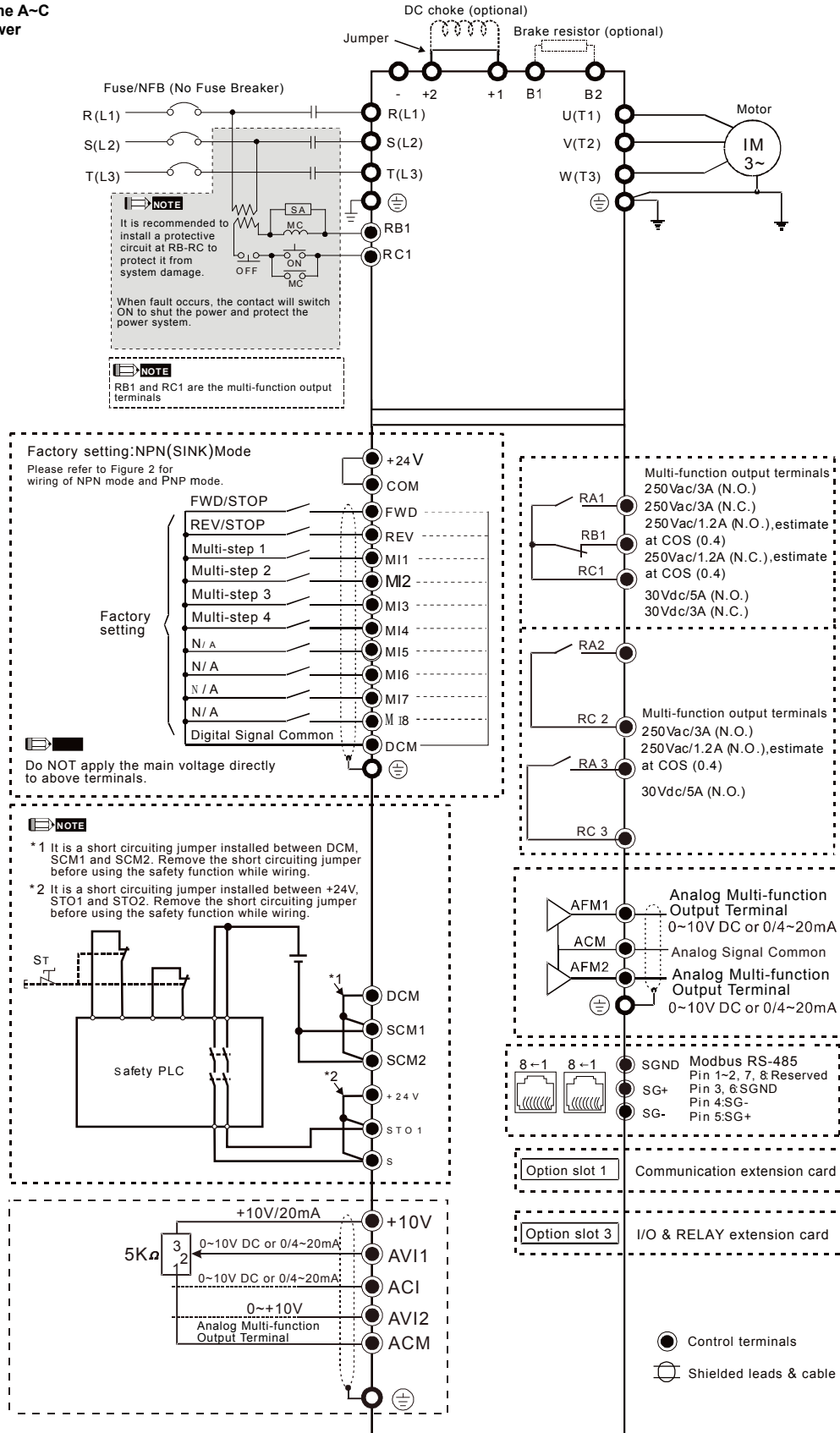

# Wiring

## CP2000 Series

Wiring Diagram for Frame D0 and above  
\*It provides 3-phase power

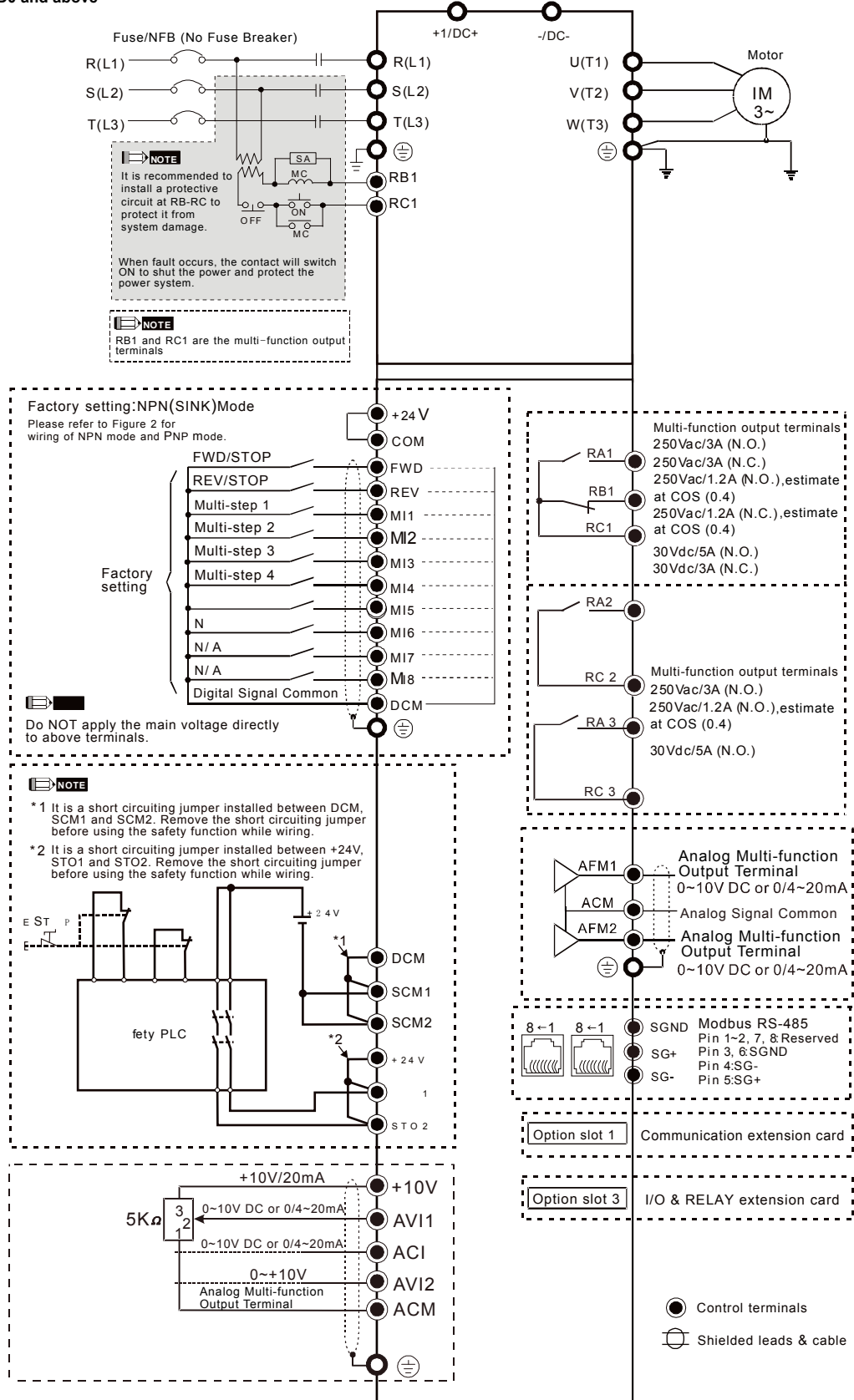

# Dimensions

## Digital Keypad

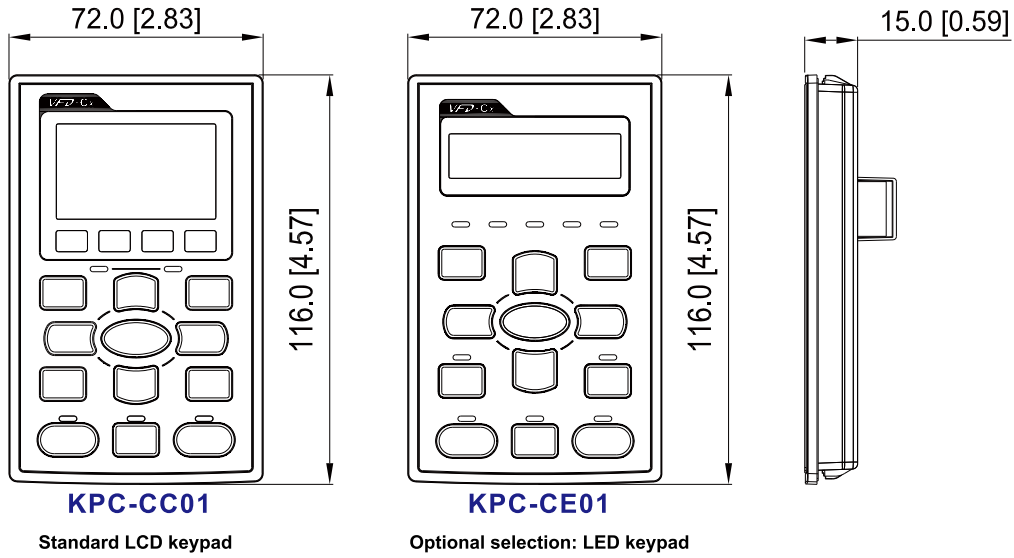

## Frame A

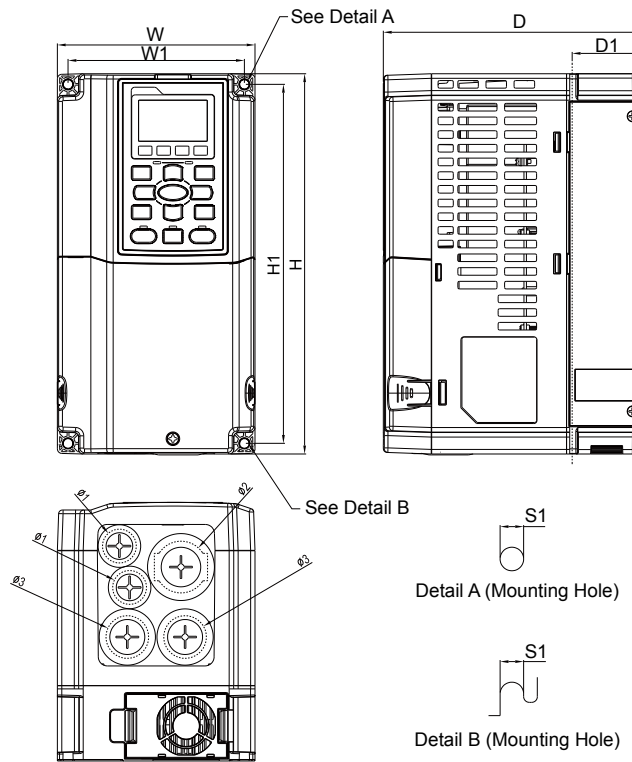

### MODEL

- VFD007CP23A-21    VFD055CP43B-21
- VFD015CP23A-21    VFD075CP43B-21
- VFD022CP23A-21    VFD007CP4EA-21
- VFD037CP23A-21    VFD015CP4EB-21
- VFD055CP23A-21    VFD022CP4EB-21
- VFD007CP43A-21    VFD037CP4EB-21
- VFD015CP43B-21    VFD040CP4EA-21
- VFD022CP43B-21    VFD055CP4EB-21
- VFD037CP43B-21    VFD075CP4EB-21
- VFD040CP43A-21

Unit : mm[inch]

Frame	W	H	D	W1	H1	D1*	Ø	Ø1	Ø2	Ø3	
A	mm	130.0	250.0	170.0	116.0	236.0	45.8	6.2	22.2	34.0	28.0
	inch	5.12	9.84	6.69	4.57	9.29	1.80	0.24	0.87	1.34	1.10

D1\*: Flange mounting

# Dimensions

## Frame B

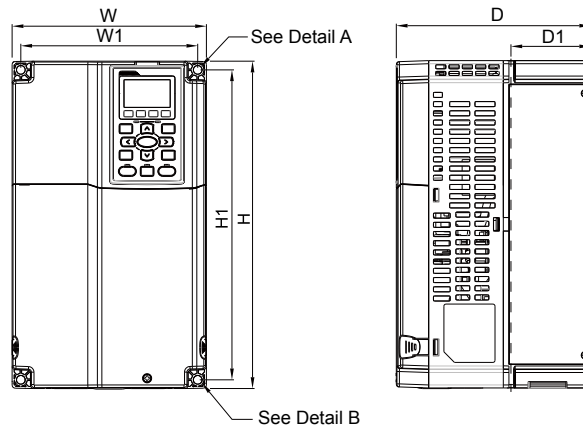

### MODEL

- VFD075CP23A-21
- VFD110CP23A-21
- VFD150CP23A-21
- VFD110CP43B-21
- VFD150CP43B-21
- VFD185CP43B-21
- VFD110CP4EB-21
- VFD150CP4EB-21
- VFD185CP4EB-21

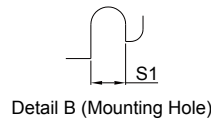
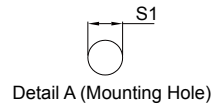
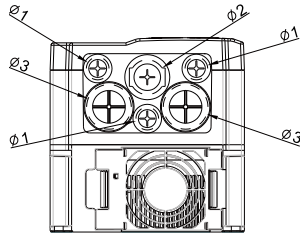

Unit : mm[inch]

Frame	W	H	D	W1	H1	D1*	S1	Ø1	Ø2	Ø3	
B1	mm	190.0	320.0	190.0	173.0	303.0	77.9	8.5	22.2	34.0	28.0
	inch	7.48	12.60	7.48	6.81	11.93	3.07	0.33	0.87	1.34	1.10

D1\*: Flange mounting

## Frame C

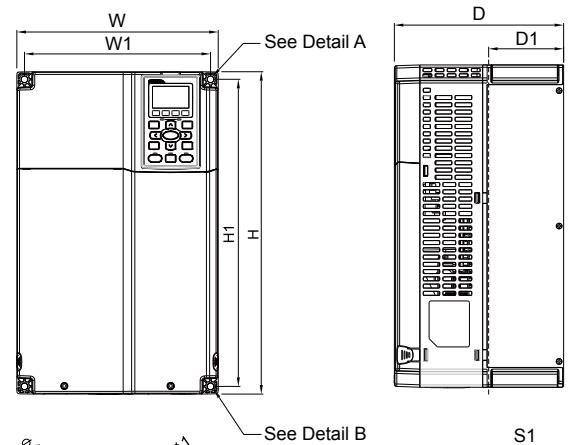

### MODEL

- VFD185CP23A-21
- VFD220CP23A-21
- VFD300CP23A-21
- VFD220CP43A-21
- VFD300CP43B-21
- VFD370CP43B-21
- VFD220CP4EA-21
- VFD300CP4EB-21
- VFD370CP4EB-21

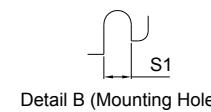
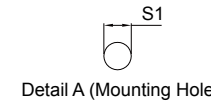
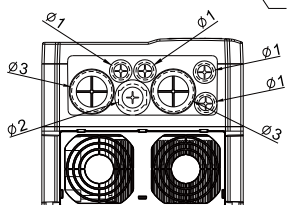

Unit : mm[inch]

Frame	W	H	D	W1	H1	D1*	S1	Ø1	Ø2	Ø3	
C1	mm	250.0	400.0	210.0	231.0	381.0	92.9	8.5	22.2	34.0	50.0
	inch	9.84	15.75	8.27	9.09	15.00	3.66	0.33	0.87	1.34	1.97

D1\*: Flange mounting

## Frame D1 / D0-1

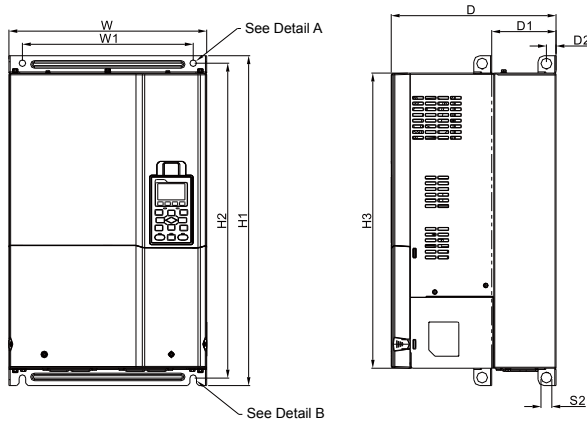

### MODEL

#### FRAME\_D1

VFD370CP23A-00  
VFD450CP23A-00  
VFD750CP43B-00  
VFD900CP43A-00

#### FRAME\_D0-1

VFD450CP43S-00  
VFD550CP43S-00

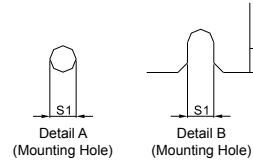
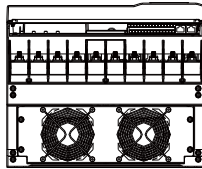

Unit : mm[inch]

Frame		W	H	D	W1	H1	H2	H3	D1*	D2	S1	S2	Ø1	Ø2	Ø3
D1	mm	330.0	-	275.0	285.0	550.0	525.0	492.0	107.2	16.0	11.0	18.0	-	-	-
	inch	12.99	-	10.83	11.22	21.65	20.67	19.37	4.22	0.63	0.43	0.71	-	-	-

Frame		W	H	D	W1	H1	H2	H3	D1*	D2	S1	S2
D0-1	mm	280.0	-	255.0	235.0	500.0	475.0	442.0	94.2	16.0	11.0	18.0
	inch	11.02	-	10.04	9.25	19.69	18.70	17.40	3.71	0.63	0.43	0.71

D1\*: Flange mounting

## Frame D2 / D0-2

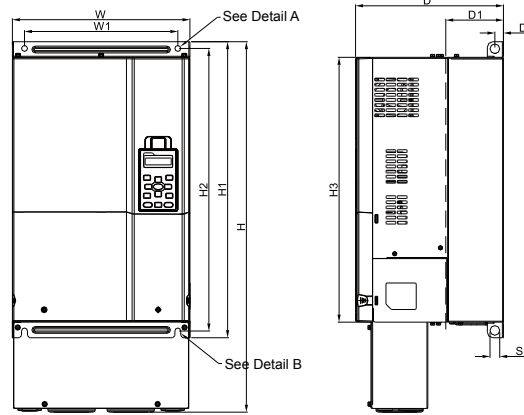

### MODEL

#### FRAME\_D2

VFD370CP23A-21  
VFD450CP23A-21  
VFD750CP43B-21  
VFD900CP43A-21

#### FRAME\_D0-2

VFD450CP43S-21  
VFD550CP43S-21

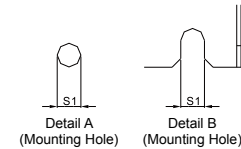
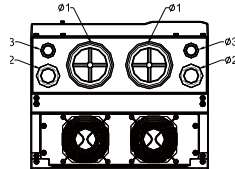

Unit : mm[inch]

Frame		W	H	D	W1	H1	H2	H3	D1*	D2	S1	S2	Ø1	Ø2	Ø3
D2	mm	330.0	688.3	275.0	285.0	550.0	525.0	492.0	107.2	16.0	11.0	18.0	76.2	34.0	22.0
	inch	12.99	27.10	10.83	11.22	21.65	20.67	19.37	4.22	0.63	0.43	0.71	3.00	1.34	0.87

Frame		W	H	D	W1	H1	H2	H3	D1*	D2	S1	S2	Ø1	Ø2	Ø3
D0-2	mm	280.0	614.4	255.0	235.0	500.0	475.0	442.0	94.2	16.0	11.0	18.0	62.7	34.0	22.0
	inch	11.02	21.19	10.04	9.25	19.69	18.70	17.40	3.71	0.63	0.43	0.71	2.47	1.34	0.87

D1\*: Flange mounting



# Dimensions

## Frame E1

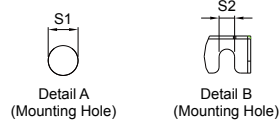
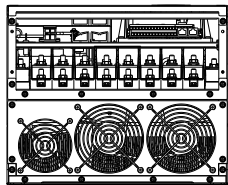
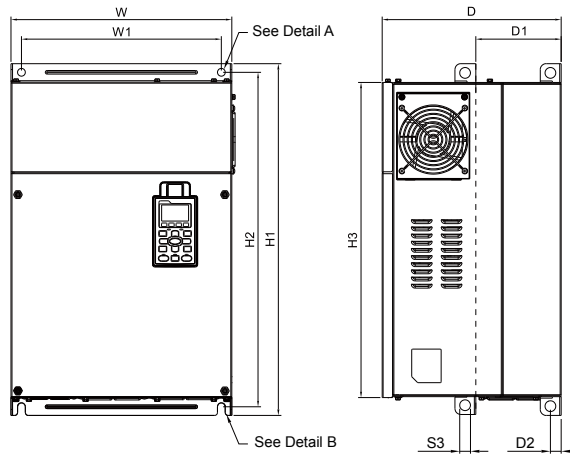

### MODEL

- VFD550CP23A-00
- VFD750CP23A-00
- VFD900CP23A-00
- VFD1100CP43A-00
- VFD1320CP43B-00

Unit : mm[inch]

Frame	W	H	D	W1	H1	H2	H3	D1*	D2	S1	S2	S3	Ø1	Ø2	Ø3	
E1	mm	370.0	-	300.0	335.0	589	560.0	528.0	143.0	18.0	13.0	13.0	18.0	-	-	-
	inch	14.57	-	11.81	13.19	23.19	22.05	20.80	5.63	0.71	0.51	0.51	0.71	-	-	-

D1\*: Flange mounting

## Frame E2

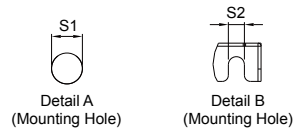
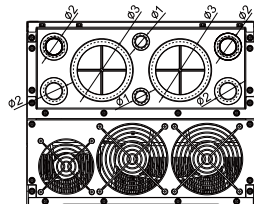
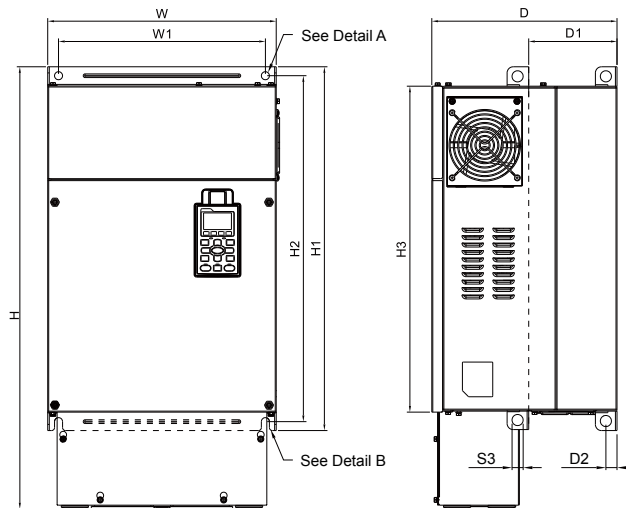

### MODEL

- VFD550CP23A-21
- VFD750CP23A-21
- VFD900CP23A-21
- VFD1100CP43A-21
- VFD1320CP43B-21

Unit : mm[inch]

Frame	W	H	D	W1	H1	H2	H3	D1*	D2	S1	S2	S3	Ø1	Ø2	Ø3	
E2	mm	370.0	715.8	300.0	335.0	589	560.0	528.0	143.0	18.0	13.0	13.0	18.0	22.0	34.0	92.0
	inch	14.57	28.18	11.81	13.19	23.19	22.05	20.80	5.63	0.71	0.51	0.51	0.71	0.87	1.34	3.62

D1\*: Flange mounting

## Frame F1

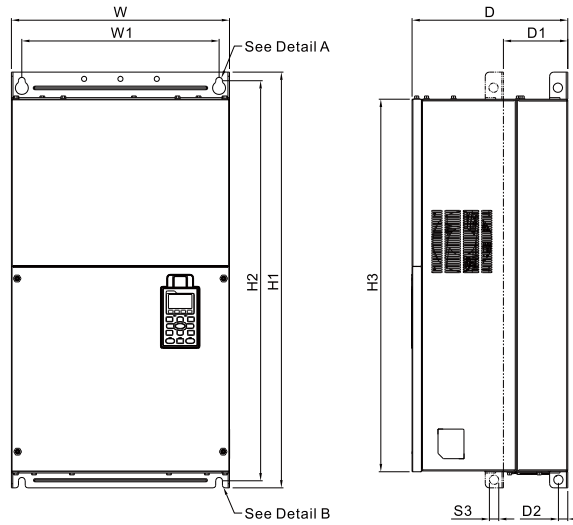

### MODEL

VFD1600CP43A-00  
VFD1850CP43B-00

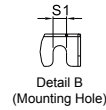
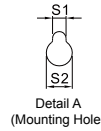
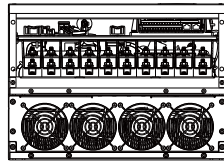

Unit : mm[inch]

Frame	W	H	D	W1	H1	H2	H3	D1*	D2	S1	S2	S3	Ø1	Ø2	Ø3	
F1	mm	420.0	-	300.0	380.0	800.0	770.0	717.0	124.0	18.0	13.0	25.0	18.0	-	-	-
	inch	16.54	-	11.81	14.96	31.50	30.32	28.23	4.88	0.71	0.51	0.98	0.71	-	-	-

D1\*: Flange mounting

## Frame F2

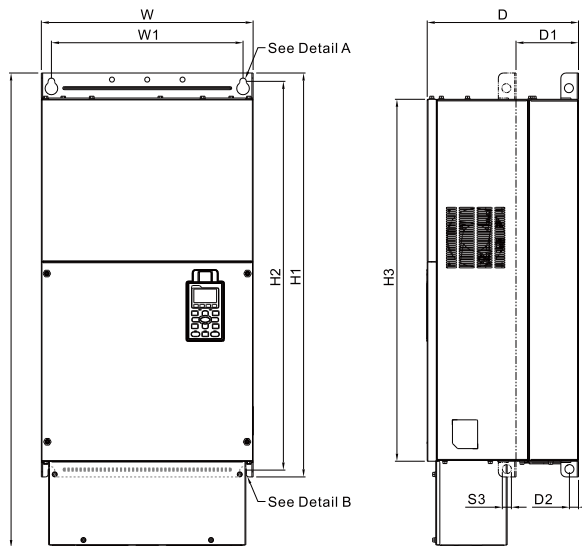

### MODEL

VFD1600CP43A-21  
VFD1850CP43B-21

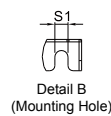
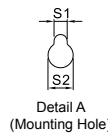
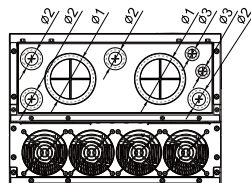

Unit : mm[inch]

Frame	W	H	D	W1	H1	H2	H3	D1*	D2	S1	S2	S3	Ø1	Ø2	Ø3	
F2	mm	420.0	940.0	300.0	380.0	800.0	770.0	717.0	124.0	18.0	13.0	25.0	18.0	92.0	35.0	22.0
	inch	16.54	37.00	11.81	14.96	31.50	30.32	28.23	4.88	0.71	0.51	0.98	0.71	3.62	1.38	0.87

D1\*: Flange mounting

# Dimensions

## Frame G1

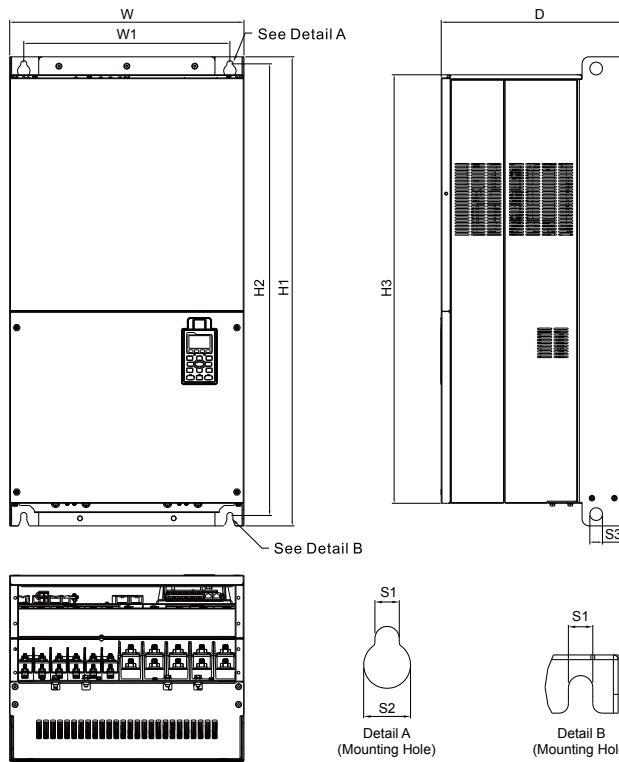

### MODEL

VFD2200CP43A-00  
VFD2800CP43A-00

Unit : mm[inch]

Frame		W	H	D	W1	H1	H2	H3	S1	S2	S3	Ø1	Ø2	Ø3
G1	mm	500.0	-	397.0	440.0	1000.0	963.0	913.6	13.0	26.5	27.0	-	-	-
	inch	19.69	-	15.63	217.32	39.37	37.91	35.97	0.51	1.04	1.06	-	-	-

## Frame G2

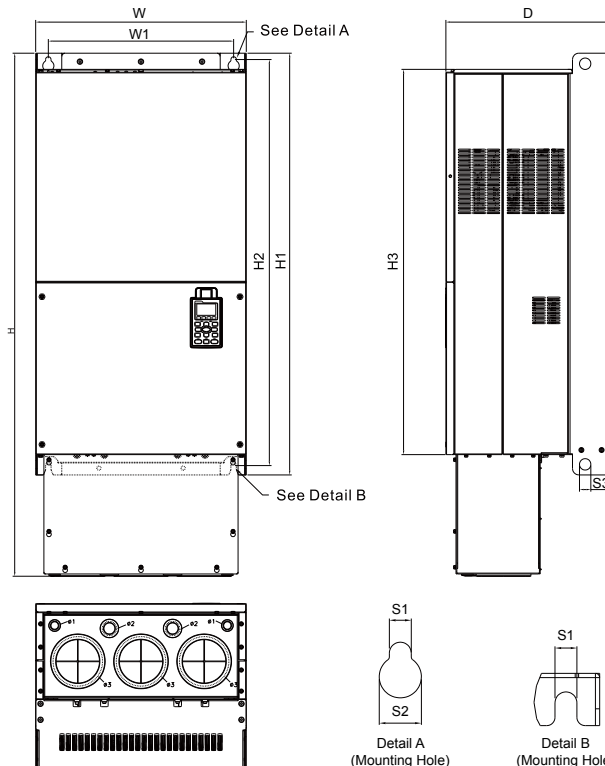

### MODEL

VFD2200CP43A-21  
VFD2800CP43A-21

Unit : mm[inch]

Frame		W	H	D	W1	H1	H2	H3	S1	S2	S3	Ø1	Ø2	Ø3
G2	mm	500.0	1240.2	397.0	440.0	1000.0	963.0	913.6	13.0	26.5	27.0	22.0	34.0	117.5
	inch	19.69	48.83	15.63	217.32	39.37	37.91	35.97	0.51	1.04	1.06	0.87	1.34	4.63

# Frame H1

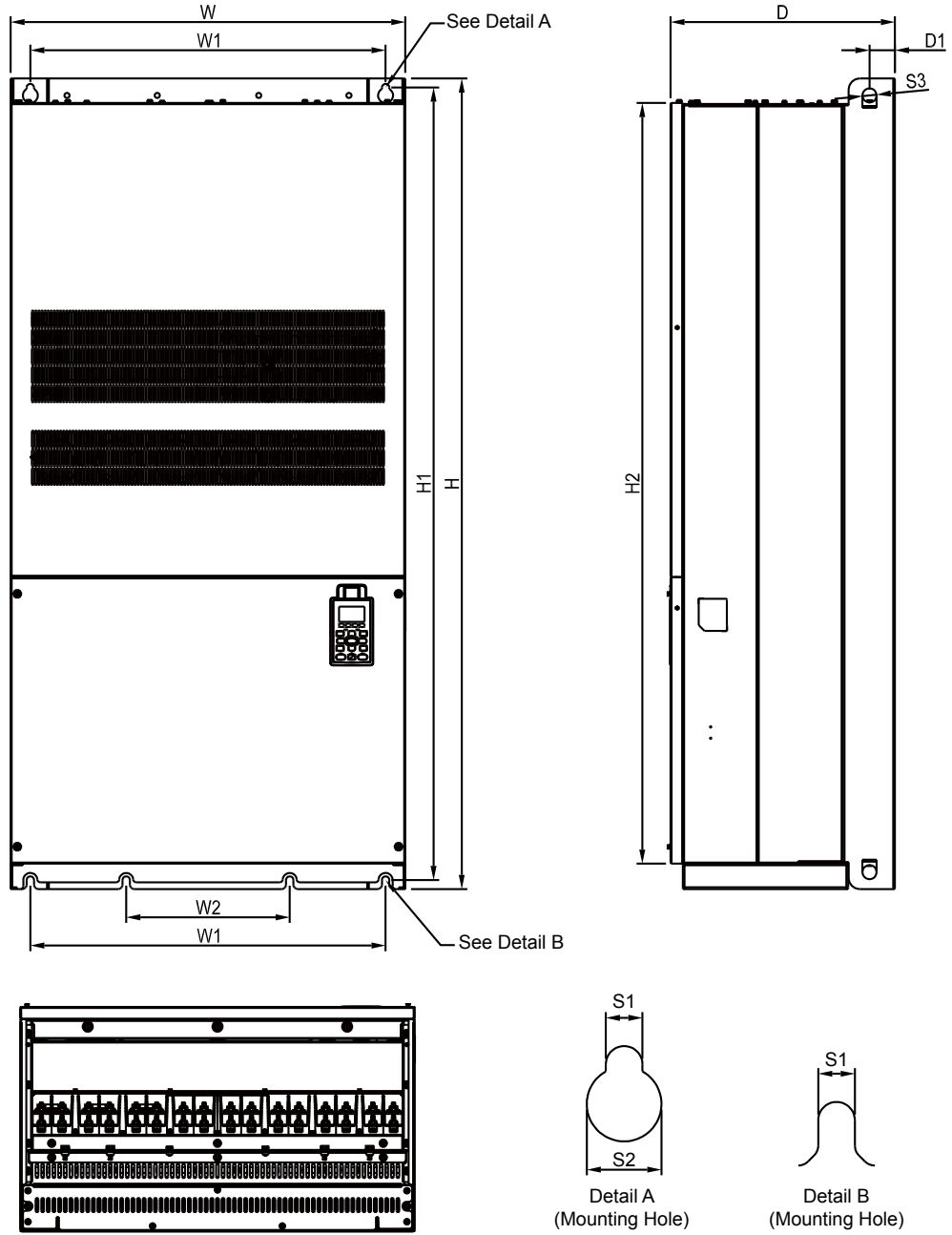

## MODEL

VFD3150CP43A-00  
 VFD3550CP43A-00  
 VFD4000CP43A-00

Unit : mm[inch]

Frame	W	H	D	W1	W2	W3	W4	W5	W6	H1	H2	H3	H4
H1	mm	700.0	1435.0	398.0	630.0	290.0	-	-	-	1403.0	1346.6	-	-
	inch	27.56	56.5	15.67	24.80	11.42	-	-	-	55.24	53.02	-	-

Frame	H5	D1	D2	D3	D4	D5	D6	S1	S2	S3	Ø1	Ø2	Ø3
H1	mm	-	45.0	-	-	-	-	13.0	26.5	25.0	-	-	-
	inch	-	1.77	-	-	-	-	0.51	1.04	0.98	-	-	-

# Dimensions

## Frame H2

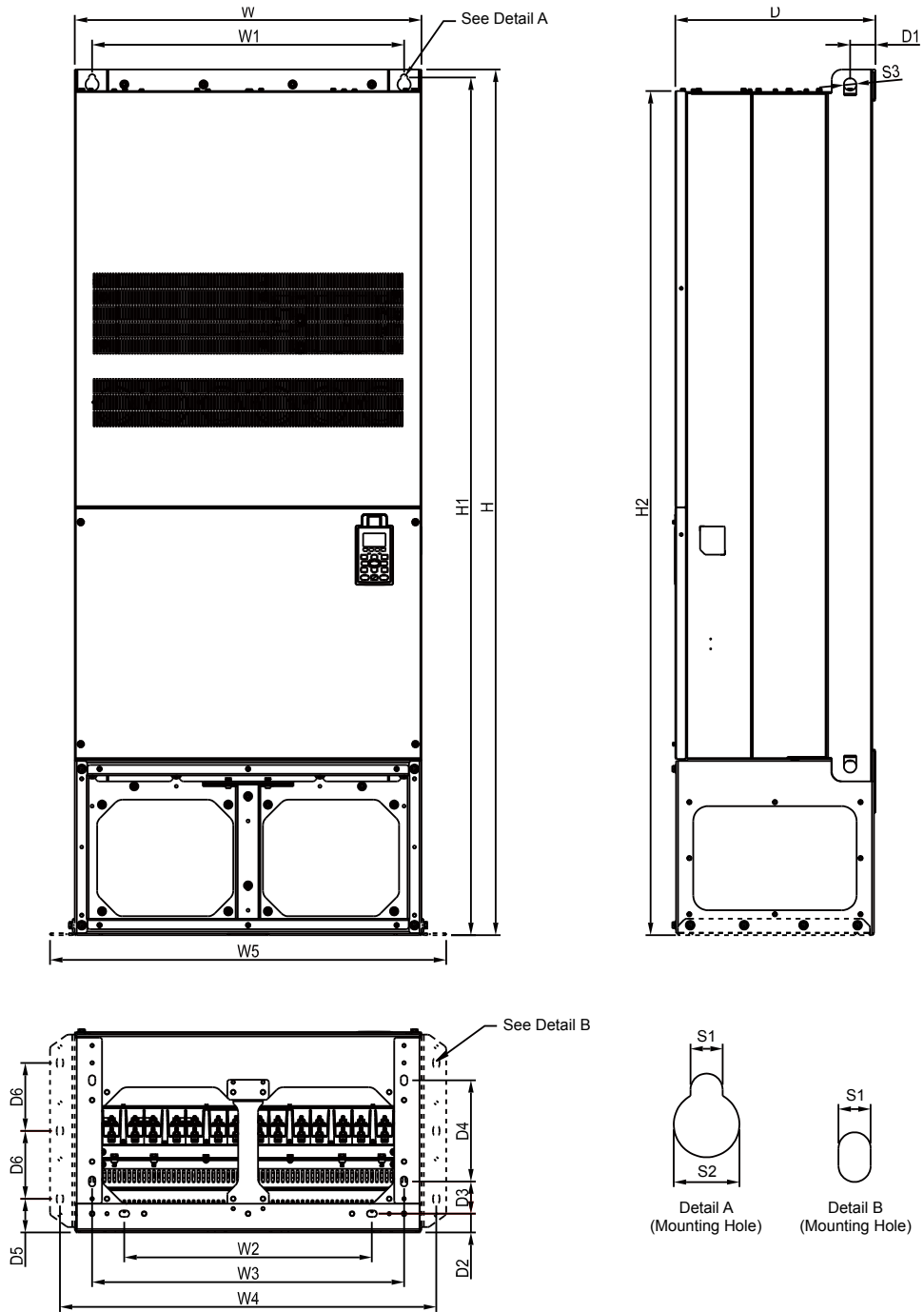

### MODEL

VFD3150CP43C-00  
 VFD3550CP43C-00  
 VFD4000CP43C-00

Unit : mm[inch]

Frame		W	H	D	W1	W2	W3	W4	W5	W6	H1	H2	H3	H4
H2	mm	700.0	1745.0	404.0	630.0	500.0	630.0	760.0	800.0	-	1729.0	1701.6	-	-
	inch	27.56	68.70	15.91	24.80	19.69	24.80	29.92	31.50	-	68.07	66.99	-	-
Frame		H5	D1	D2	D3	D4	D5	D6	S1	S2	S3	Ø1	Ø2	Ø3
H2	mm	-	51.0	38.0	65.0	204.0	68.0	137.0	13.0	26.5	25.0	-	-	-
	inch	-	2.01	1.50	2.56	8.03	2.68	5.39	0.51	1.04	0.98	-	-	-

### Frame H3

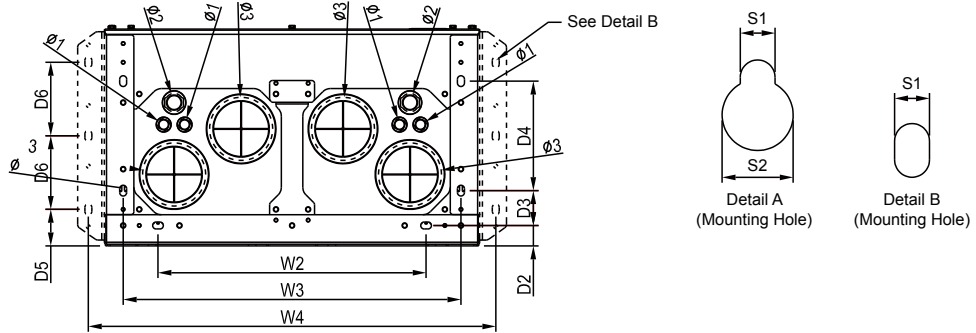
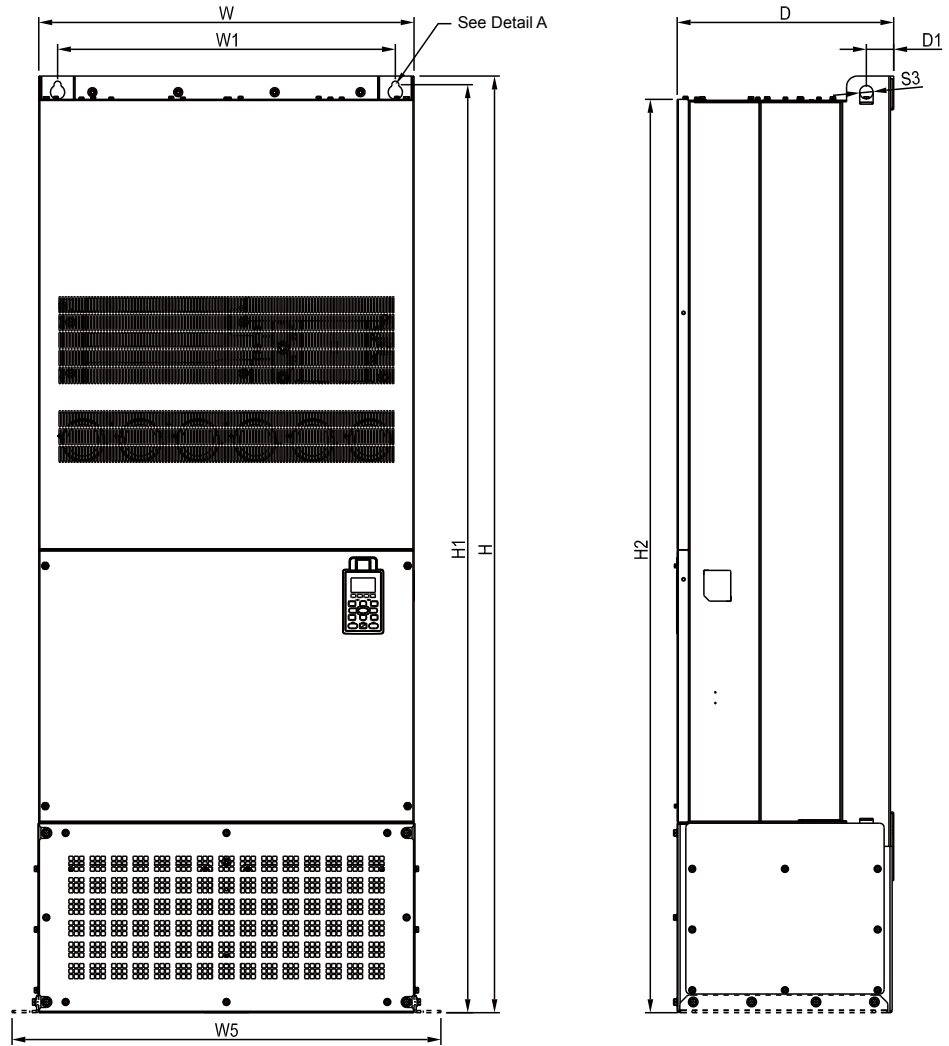

### MODEL

VFD3150CP43C-21  
 VFD3550CP43C-21  
 VFD4000CP43C-21

Unit : mm[inch]

Frame	W	H	D	W1	W2	W3	W4	W5	W6	H1	H2	H3	H4	
H3	mm	700.0	1745.0	404.0	630.0	500.0	630.0	760.0	800.0	-	1729.0	1701.6	-	-
	inch	27.56	68.70	15.91	24.80	19.69	24.80	29.92	31.50	-	68.07	66.99	-	-

Frame	H5	D1	D2	D3	D4	D5	D6	S1	S2	S3	Ø1	Ø2	Ø3	
H3	mm	-	51.0	38.0	65.0	204.0	68.0	137.0	13.0	26.5	25.0	22.0	34.0	117.5
	inch	-	2.01	1.50	2.56	8.03	2.68	5.39	0.51	1.04	0.98	0.87	1.34	4.63

# Option Cards

## EMC-D42A

	Terminals	Descriptions
 <p>I/O Extension Card</p>	COM	Common for multi-function input terminals Select SINK (NPN) / SOURCE (PNP) in J1 jumper / external power supply
	MI10~ MI13	Refer to parameters 02-26~02-29 to program the multi-function inputs MI10~MI13. Internal power is applied from terminal E24: +24Vdc±5% 200mA, 5W External power +24Vdc: max. voltage 30Vdc, min. voltage 19Vdc, 30W ON: the activation current is 6.5mA; OFF: leakage current tolerance is 10 A
	MO10~MO11	Multi-function output terminals (photocoupler) Duty-cycle: 50%; Max. output frequency: 100Hz Max. current: 50mA; Max. voltage: 48Vdc
	MXM	Common for multi-function output terminals MO10, MO11(photocoupler) Max 48Vdc 50mA

## EMC-D611A

	Terminals	Descriptions
 <p>I/O Extension Card</p>	AC	AC power common for multi-function input terminal (Neutral)
	MI10~MI15	Refer to Pr. 02.26~ Pr. 02.31 for multi-function input selection Input voltage: 100~130VAC; Input frequency: 57~63Hz Input impedance: 27Kohm Terminal response time: ON: 10ms; OFF: 20ms

## EMC-R6AA

	Terminals	Descriptions
 <p>Relay Extension Card</p>	RA10~RA15 RC10~RC15	Refer to Pr. 02.36~ Pr. 02.41 for multi-function input selection Resistive load: 3A(N.O.)/250VAC 5A(N.O.)/30Vdc Inductive load (COS 0.4) 2.0A(N.O.)/250VAC 2.0A(N.O.)/30Vdc It is used to output each monitor signal, such as for drive in operation, frequency attained or overload indication.

## EMC-BPS01

	Terminals	Descriptions
 <p>Power Shift Card</p>	24V GND	Input Power Specification: 24V±5% Maximum input current: 0.5A Note: (1) Do not connect the control terminal +24V terminal directly to the EMC-BPS01 input terminal 24V. (2) Do not connect the control terminal GND directly to the EMC-BPS01 input terminal GND to ensure a proper grounding.

## CMC-MOD01



### Features

- MDI/MDI-X auto-detect
- Virtual serial port
- Supports MODBUS TCP protocol
- E-mail alarm
- Baud rate: 10 / 100Mbps auto-detect
- AC motor drive keypad / Ethernet configuration

### Network Interface

Interface	RJ-45 with Auto MDI/MDIX	Transmission speed	10/100 Mbps Auto-Detect
Number of ports	1 Port	Network protocol	ICMP, IP, TCP, UDP, DHCP, SMTP, MODBUS OVER TCP/IP, Delta Configuration
Transmission method	IEEE 802.3, IEEE 802.3u		
Transmission cable	Category 5e shielding 100M		

## CMC-EIP01



### Features

- MDI/MDI-X auto-detect
- Supports MODBUS TCP and Ethernet/IP protocol
- Baud rate: 10/100Mbps auto-detect
- AC motor drive keypad/Ethernet configuration
- Virtual serial port

### Network Interface

Interface	RJ-45 with Auto MDI/MDIX	Transmission speed	10/100 Mbps Auto-Detect
Number of ports	1 Port	Network protocol	ICMP, IP, TCP, UDP, DHCP, SMTP, MODBUS OVER TCP/IP, Delta Configuration
Transmission method	IEEE 802.3, IEEE 802.3u		
Transmission cable	Category 5e shielding 100M		

## CMC-PD01



### Features

- Supports PZD control data exchange
- Supports PKW polling AC motor drive parameters
- Supports user diagnosis function
- Auto-detects baud rates; supports Max. 12Mbps

### PROFIBUS DP Connector

Interface	DB9 connector
Transmission method	High-speed RS-485
Transmission cable	Shielded twisted pair cable
Electrical isolation	500VDC

### Communication

Message type	Cyclic data exchange
Module name	CMC-PD01
GSD document	DELA08DB.GSD
Company ID	08DB (HEX)
Serial transmission speed supported (auto-detection)	9.6kbps; 19.2kbps; 93.75kbps; 187.5kbps; 125kbps; 250kbps; 500kbps; 1.5Mbps; 3Mbps; 6Mbps; 12Mbps (bits per second)





## CMC-DN01



### Features

- Based on the high-speed communication interface of Delta HSSP protocol, able to conduct immediate control of AC motor drive
- Supports Group 2 only connection and polling I/O data exchange
- For I/O mapping, supports Max. 32 words of input and 32 words of output
- Supports EDS file configuration in DeviceNet configuration software
- Supports all baud rates on DeviceNet bus: 125kbps, 250kbps, 500kbps and extendable serial transmission speed mode
- Node address and serial transmission speed can be set up on AC motor drive
- Power supplied from AC motor drive

### DeviceNet Connector

Interface	5-PIN open removable connector. Of 5.08mm PIN interval
Transmission method	CAN
Transmission cable	Shielded twisted pair cable (with 2 power cables)
Transmission speed	125kbps, 250kbps, 500kbps and extendable serial transmission speed mode
Network protocol	DeviceNet protocol

### AC Motor Drive Connection Port

Interface	50 PIN communication terminal
Transmission method	SPI communication
Terminal function	1. Communicating with AC motor drive 2. Transmitting power supply from AC motor drive
Communication protocol	Delta HSSP protocol

## EMC-COP01



### RJ-45 Pin Definition

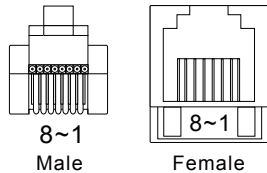

Pin	Pin name	Definition
1	CAN_H	CAN_H bus line (dominant high)
2	CAN_L	CAN_L bus line (dominant low)
3	CAN_GND	Ground/0V/V-
7	CAN_GND	Ground/0V/V-

### Specifications

Interface	RJ-45
Number of ports	1 Port
Transmission method	CAN
Transmission cable	CAN standard cable
Transmission speed	1M 500k 250k 125k 100k 50k
Communication protocol	CANopen



## CANopen Communication Cable

Model: TAP-CB05, TAP-CB10

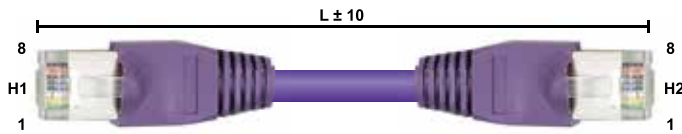

Title	Part No.	L	
		mm	inch
1	TAP-CB05	500±10	19±0.4
2	TAP-CB10	1000±10	39±0.4

## CANopen Breakout Box

Model: TAP-CN03



## Digital Keypad Accessories: RJ45 Extension Leads and CMC-EIP01 Cables



Applicable Models: CBC-K3FT, CBC-K5FT, CBC-K7FT, CBC-K10F, CBC-K16FT

Title	Part No.	Explanation
1	CBC-K3FT	RJ45 extension lead, 3 feet (approximately 0.9m)
2	CBC-K5FT	RJ45 extension lead, 5 feet (approximately 1.5m)
3	CBC-K7FT	RJ45 extension lead, 7 feet (approximately 2.1m)
4	CBC-K10FT	RJ45 extension lead, 10 feet (approximately 3m)
5	CBC-K16FT	RJ45 extension lead, 16 feet (approximately 4.9m)



# Ordering information

Frame Size	Power Range	Model Name List		
<b>Frame A</b> 	<b>230V:</b> 0.75~5.5kW  <b>460V:</b> 0.75~7.5kW	VFD007CP23A-21 VFD015CP23A-21 VFD022CP23A-21 VFD037CP23A-21 VFD055CP23A-21	VFD007CP43A-21 VFD015CP43B-21 VFD022CP43B-21 VFD037CP43B-21 VFD040CP43A-21 VFD055CP43B-21 VFD075CP43B-21	VFD007CP4EA-21 VFD015CP4EB-21 VFD022CP4EB-21 VFD037CP4EB-21 VFD040CP4EA-21 VFD055CP4EB-21 VFD075CP4EB-21
<b>Frame B</b> 	<b>230V:</b> 7.5kW~15kW  <b>460V:</b> 11kW~18.5kW	VFD075CP23A-21 VFD110CP23A-21 VFD150CP23A-21	VFD110CP43B-21 VFD150CP43B-21 VFD185CP43B-21	VFD110CP4EB-21 VFD150CP4EB-21 VFD185CP4EB-21
<b>Frame C</b> 	<b>230V:</b> 18.5kW~30kW  <b>460V:</b> 22kW~37kW	VFD185CP23A-21 VFD220CP23A-21 VFD300CP23A-21	VFD220CP43A-21 VFD300CP43B-21 VFD370CP43B-21	VFD220CP4EA-21 VFD300CP4EB-21 VFD370CP4EB-21
<b>Frame D</b> 	<b>230V:</b> 37kW~45kW  <b>460V:</b> 45kW~90kW	<b>Frame_D0-1</b> VFD450CP43S-00 VFD550CP43S-00  <b>Frame_D1</b> VFD370CP23A-00 VFD450CP23A-00 VFD750CP43B-00 VFD900CP43A-00	<b>Frame_D0-2</b> VFD450CP43S-21 VFD550CP43S-21  <b>Frame_D2</b> VFD370CP23A-21 VFD450CP23A-21 VFD750CP43B-21 VFD900CP43A-21	
<b>Frame E</b> 	<b>230V:</b> 55kW~90kW  <b>460V:</b> 110kW~132kW	<b>Frame_E1</b> VFD550CP23A-00 VFD750CP23A-00 VFD900CP23A-00 VFD1100CP43A-00 VFD1320CP43B-00	<b>Frame_E2</b> VFD550CP23A-21 VFD750CP23A-21 VFD900CP23A-21 VFD1100CP43A-21 VFD1320CP43B-21	
<b>Frame F</b> 	<b>460V:</b> 160kW~185kW	<b>Frame_F1</b> VFD1600CP43A-00 VFD1850CP43B-00	<b>Frame_F2</b> VFD1600CP43A-21 VFD1850CP43B-21	

Frame Size	Power Range	Model Name List		
<b>Frame G</b> 	<b>460V:</b> 220kW~280kW	<b>Frame_G1</b> VFD2200CP43A-00 VFD2800CP43A-00	<b>Frame_G2</b> VFD2200CP43A-21 VFD2800CP43A-21	
<b>Frame H</b> 	<b>460V:</b> 315kW~400kW	<b>Frame_H1</b> VFD3150CP43A-00 VFD3550CP43A-00 VFD4000CP43A-00	<b>Frame_H2</b> VFD3150CP43C-00 VFD3550CP43C-00 VFD4000CP43C-00	<b>Frame_H3</b> VFD3150CP43C-21 VFD3550CP43C-21 VFD4000CP43C-21

## Model Name

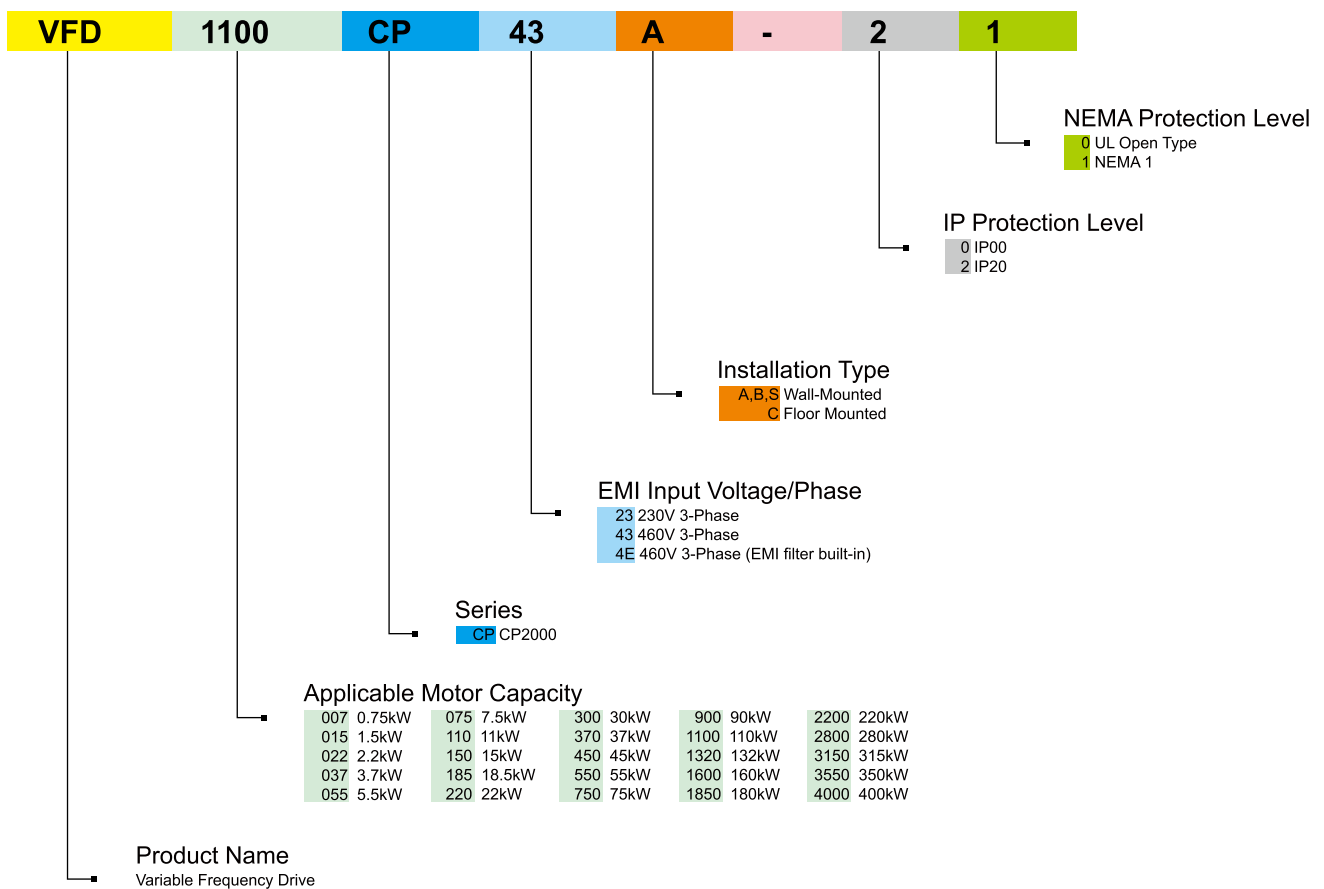



## Attention

### Standard Motors

**Used with 400V Standard Motors**  
It is recommended to add an AC output reactor when using with a 400V standard motor to prevent damage to motor insulation.

#### Torque Characteristics and Temperature Rise

When a standard motor is drive controlled, the motor temperature will be higher than with DOL operation.

Please reduce the motor output torque when operating at low speeds to compensate for less cooling efficiency.

For continuous constant torque at low speeds, external forced motor cooling is recommended.

#### Vibration

When the motor drives the machine, resonances may occur, including machine resonances.

Abnormal vibration may occur when operating a 2-pole motor at 60Hz or higher.

#### Noise

When a standard motor is drive controlled, the motor noise will be higher than with DOL operation.

To lower the noise, please increase the carrier frequency of the drive. The motor fan can be very noisy when the motor speed exceeds 60Hz.

### Special Motors

#### High-speed Motor

To ensure safety, please try the frequency setting with another motor before operating the high-speed motor at 120Hz or higher.

#### Explosion-proof Motor

Please use a motor and drive that comply with explosion-proof requirements.

#### Submersible Motor & Pump

The rated current is higher than that of a standard motor.

Please check before operation and select the capacity of the AC motor drive carefully.

The motor temperature characteristics differ from a standard motor, please set the motor thermal time constant to a lower value.

#### Brake Motor

When the motor is equipped with a mechanical brake, the brake should be powered by the mains supply.

Damage may occur when the brake is powered by the drive output. Please DO NOT drive the motor with the brake engaged.

#### Gear Motor

In gearboxes or reduction gears, lubrication may be reduced if the motor is continuously operated at low speeds.

Please DO NOT operate in this way.

#### Synchronous Motor

These motors need suitable software for control. Please contact Delta for more information.

#### Single-phase Motor

Single-phase motors are not suitable for being operated by an AC Motor Drive. Please use a 3-phase motor instead when necessary.

### Environmental Conditions

#### Installation Position

1. The drive is suitable for installation in a place with ambient temperature from -10 to 50°C.
2. The surface temperature of the drive and brake resistor will rise under specific operation conditions. Therefore, please install the drive on materials that are noncombustible.
3. Ensure that the installation site complies with the ambient conditions as stated in the manual.

### Wiring

#### Limit of Wiring Distance

For the remote operation, please use twist-shielding cable and the distance between the drive and control box should be less than 20m.

#### Maximum Motor Cable Length

Motor cables that are too long may cause overheating of the drive or current peaks due to stray capacitance.  
Please ensure that the motor cable is less than 30m.  
If the cable length can't be reduced, please lower the carrier frequency or use an AC reactor.

#### Choose the Right Cable

Please refer to current value to choose the right cable section with enough capacity or use recommended cables.

#### Grounding

Please ground the drive completely by using the grounding terminal.

### How to Choose the Drive Capacity

#### Standard Motor

Please select the drive according to applicable motor rated current listed in the drive specification.

Please select the next higher power AC drive in case higher starting torque or quick acceleration/deceleration is needed.

#### Special Motor

Please select the drive according to: Rated current of the drive > rated current of the motor

### Transportation and Storage

Please transport and store the drive in a place that meets environment specifications.

### Peripheral Equipment

#### Molded-Case Circuit Breakers (MCCB)

Please install the recommended MCCB or ELCB in the main circuit of the drive and make sure that the capacity of the breaker is equal to or lower than the recommended one.

#### Add a Magnetic Contactor(MC) in the Output Circuit

When a MC is installed in the output circuit of the drive to switch the motor to commercial power or other purposes, please make sure that the drive and motor are completely stopped and remove the surge absorbers from the MC before switching it.

#### Add a Magnetic Contactor (MC) in the Input Circuit

Please only switch the MC ONCE per hour or it may damage the drive. Please use RUN/STOP signal to switch many times during motor operation.

#### Motor Protection

The thermal protection function of the drive can be used to protect the motor by setting the operation level and motor type (standard motor or variable motor).  
When using a high-speed motor or a water-cooled motor the thermal time constant should be set to a lower value.

When using a longer cable to connect the motor thermal relay to a motor, high-frequency currents may enter via the stray capacitance. It may result in malfunctioning of the relay as the real current is lower than the setting of thermal relay. Under this condition, please lower the carrier frequency or add an AC reactor to solve this.

#### DO NOT Use Capacitors to Improve the Power Factor

Use a DC reactor to improve the power factor of the drive. Please DO NOT install power factor correction capacitors on the main circuit of the drive to prevent motor faults due to over current.

#### Do NOT Use Surge Absorber

Please DO NOT install surge absorbers on the output circuit of the drive.

#### Lower the Noise

To ensure compliance with EMC regulations, usually a filter and shielded wiring is used to lower the noise.

#### Method Used to Reduce the Surge Current

Surge currents may occur in the phase-lead capacitor of the power system, causing an overvoltage when the drive is stopped or at low loads.

It is recommended to add a DC reactor to the drive.

# Global Operations



▲ Factories 2 ■ Branch Offices



62 ● R&D Centers 5 ■ Distributors 725



Smarter. Greener. Together.

### **Industrial Automation Headquarters**

#### **Delta Electronics, Inc.**

Taoyuan Technology Center  
18 Xinglong Road, Taoyuan District,  
Taoyuan City 33068, Taiwan (R.O.C.)  
TEL: 886-3-362-6301 / FAX: 886-3-371-6301

### **Asia**

#### **Delta Electronics (Jiangsu) Ltd.**

Wujiang Plant 3  
1688 Jiangxing East Road,  
Wujiang Economic Development Zone  
Wujiang City, Jiang Su Province, P.R.C. 215200  
TEL: 86-512-6340-3008 / FAX: 86-769-6340-7290

#### **Delta Greentech (China) Co., Ltd.**

238 Min-Xia Road, Pudong District,  
Shanghai, P.R.C. 201209  
TEL: 86-21-58635678 / FAX: 86-21-58630003

#### **Delta Electronics (Japan), Inc.**

Tokyo Office  
2-1-14 Minato-ku Shibadaimon,  
Tokyo 105-0012, Japan  
TEL: 81-3-5733-1111 / FAX: 81-3-5733-1211

#### **Delta Electronics (Korea), Inc.**

1511, Byucksan Digital Valley 6-cha, Gasan-dong,  
Geumcheon-gu, Seoul, Korea, 153-704  
TEL: 82-2-515-5303 / FAX: 82-2-515-5302

#### **Delta Electronics Int'l (S) Pte Ltd.**

4 Kaki Bukit Ave 1, #05-05, Singapore 417939  
TEL: 65-6747-5155 / FAX: 65-6744-9228

#### **Delta Electronics (India) Pvt. Ltd.**

Plot No 43 Sector 35, HSIIDC  
Gurgaon, PIN 122001, Haryana, India  
TEL : 91-124-4874900 / FAX : 91-124-4874945

### **Americas**

#### **Delta Products Corporation (USA)**

Raleigh Office  
P.O. Box 12173, 5101 Davis Drive,  
Research Triangle Park, NC 27709, U.S.A.  
TEL: 1-919-767-3800 / FAX: 1-919-767-8080

#### **Delta Greentech (Brasil) S.A.**

Sao Paulo Office  
Rua Itapeva, 26 - 3° andar Edificio Itapeva One-Bela Vista  
01332-000-São Paulo-SP-Brazil  
TEL: 55 11 3568-3855 / FAX: 55 11 3568-3865

### **Europe**

#### **Deltronics (The Netherlands) B.V.**

Eindhoven Office  
De Witbogt 20, 5652 AG Eindhoven, The Netherlands  
TEL: 31-40-2592850 / FAX: 31-40-2592851

\*We reserve the right to change the information in this catalogue without prior notice.